



EVI-D70 EVI-D70P

REMOTE PAN TILT ZOOM VIDEO CAMERA

Component/OEM

Sony continues to add choice and flexibility to its industry-leading pan/tilt/zoom camera line up with the introduction of the EVI-D70 and EVI-D70P colour video cameras. With outstanding sensitivity of 1 lux, they can be used indoors or outdoors, even in poorest light.

The EVI-D70 and EVI-D70P combine a high quality colour video camera with the flexibility of a remote pan/tilt/zoom operation, all in a compact easy-to-use package. Incorporating an 18x optical zoom lens, these cameras allow a user to zoom in on a small or distant object with exceptional clarity. Compared to their predecessors, the EVI-D30/D31, the EVI-D70 and EVI-D70P cameras offer a wider pan/tilt range, and a faster pan/tilt mechanism. Above all, these cameras are ceiling-mountable - a first for the popular Sony EVI cameras.

The EVI-D70 and EVI-D70P are also equipped with a variety of convenient features such as Auto ICR function, Alarm function and RS-232C/422 serial control, making them ideal for any remote shooting applications such as distance learning, indoor and outdoor security systems, courtrooms, event venues, concert halls, and more.

Superb Picture Quality with EXview HAD CCD

The adoption of Sony EXview HAD CCD improves basic camera performance. For example, these cameras offer superb sensitivity of 1 lx (typical), and a low smear level and D-range.

Auto ICR (IR Cut Filter Removal) Function

The Auto ICR function automatically switches the settings to attach or remove the IR Cut filter for increased sensitivity. With a set level of darkness, the IR Cut filter is automatically disabled (ICR ON), and the infrared sensitivity is increased. With a set level of brightness, the filter is automatically enabled (ICR OFF). The ICR automatically engages depending on the ambient light, allowing the cameras to be effective both in day and night environments.

RS-232C or RS-422 Serial Control (VISCA Command)

All camera settings and pan/tilt/zoom functions can be controlled remotely via a PC. With the RS-232C connection, maximum cable length can be extended to 15 m (50 feet), while the RS-422 connection extends this further to 1200 m (4000 feet).

Features

- 216x Zoom Ratio (18x Optical, 12x Digital)
- Wide Range, High Speed Pan/Tilt
 - Pan angle: -170° to +170°
(Max. pan speed: 100°/s)
 - Tilt angle: -30° to +90°
(Max. tilt speed: 90°/s)
- Superb Picture Quality With EXview HAD CCD™
 - Minimum illumination: 1 lx
 - Horizontal resolution:
470 TV lines (EVI-D70)
460 TV lines (EVI-D70P)
- Desktop or Ceiling Mount Installation
- Auto ICR Function
- Alarm Function
- RS-232C or RS-422 Serial Control (VISCA™ command)
- Auto Power-Off/Night power-Off Function
- Daisy Chain Capability (Up to Seven Cameras)
- Six-Position Preset
- Multi-Function IR Remote Commander® Unit
- EVI-D30/D31 Emulation Mode

CHANGING

THE WAY

BUSINESS

COMMUNICATES

EVI-D70/D70P SPECIFICATIONS

Alarm Function and AE Spot Setting

The EVI-D70 and EVI-D70P cameras provide an alarm function that can detect changes within a user-designated area of an image. When a change in AF, AE or both is detected, these cameras output an alarm trigger signal to the external equipment via the VISCA protocol. In combination with the Spot AE function, these cameras also detect changes in the luminance level, and they output an alarm signal. The detecting area can be applied to any of 16 vertical and 16 horizontal blocks.

* Using any of the pan/tilt/zoom functions will disable the alarm.

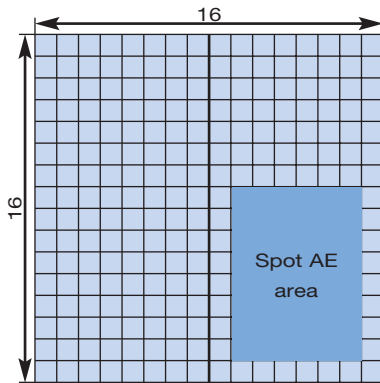

AE Spot Setting

	EVI-D70	EVI-D70P
Signal system	NTSC	PAL
Image sensor	1/4 type EXview HAD CCD	
Number of effective pixels (H x V)	768 x 494	752 x 582
Horizontal resolution	470 TV lines (wide end)	460 TV lines (wide end)
Lens	18x zoom, f=4.1 mm (wide) to 73.8 (tele), F1.4 to F3.0	
Horizontal angle of view	2.7° (tele end) to 48° (wide end)	
Minimum object distance	10 mm (wide end), 800 mm (tele end)	
Minimum illumination	1 lx (F1.4)	
Auto exposure	Auto/Manual/Priority AE, Exposure compensation, Back-light compensation	
Shutter speed	1 to 1/10,000 s	
Gain	Auto/Manual (-3 to +28 dB, 2 dB steps)	
White balance	Auto/ATW/Indoor/Outdoor/One push/Manual	
S/N ratio	More than 50 dB	
Pan/tilt	Pan: ±170° (Max. speed: 100°/s), Tilt: -30° to +90° (Max. speed: 90°/s)	
Position preset	6 positions	
Picture effect	Neg. Art, Black & White	
Video output	VBS, Y/C	
Control terminal	RS-232C (8-pin mini DIN)/RS-422 (9-pin) control (VISCA), baud rate: 9.6 Kb/s, 38.4 Kb/s	
Power requirement	DC 10.8 to 13.2 V	
Power consumption	12 W	
Operating temperature	0 to 40°C (32 to 40°F)	
Storage temperature	-20 to +60°C (-4 to +140°F)	
Dimensions (W x H x D)	132 x 144 x 144 mm (5 1/4 x 5 3/4 x 5 3/4 inches)	
Mass	950 g (2 lb 2 oz)	
Supplied accessories	AC adaptor, IR remote commander unit, Ceiling bracket, Operating instructions	

PAN/TILT RANGE

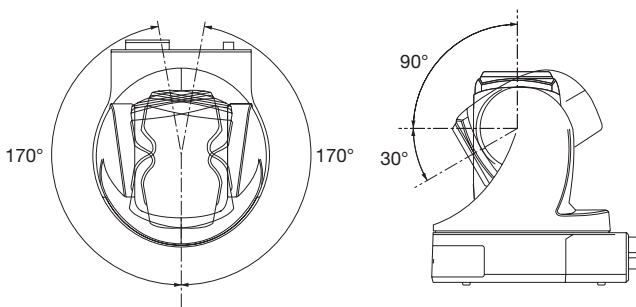

DIMENSIONS

Unit: mm (inches)

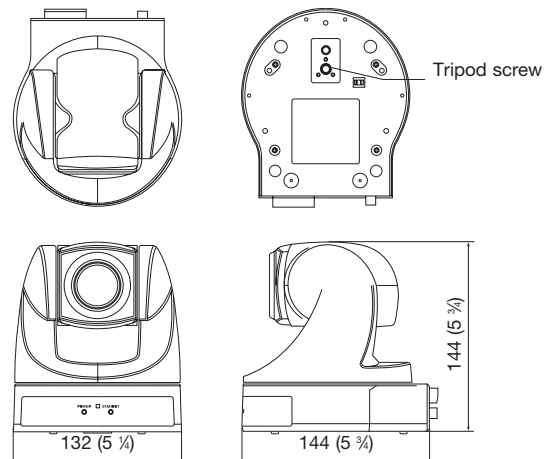

Sony Contacts

ISS for Central Zone+49 221 537 3668
(Austria, Eastern Europe, Germany, Netherlands, German-speaking Switzerland)

ISS for Nordic Zone+45 43 557 067
(Baltics, Denmark, Finland, Norway, Sweden)

ISS for Other Zone+44 1932 816 315
(UK, Ireland, Greece, Israel, South Africa)

ISS for South Zone+33 1 55 90 40 74
(Belgium, France, Italy, Portugal, Spain, French-speaking Switzerland)

ISS for Italy+39 (0) 6 334 372 27

SONY

www.sonybiz.net/vision

SONY BUSINESS EUROPE

All rights reserved.

Reproduction in whole or in part without written permission is prohibited. Design, features, and specifications are subject to change without notice.

All non-metric weights and measurements are approximate.

Sony, EXview HAD CCD, VISCA and Remote Commander are trademarks of Sony Corporation. EVI-D70/P/GB-15/10/2003